

Profi- Konsolenausführung

CNC-Messmaschine Typ 0181,
DCC- Measuring machine type 0181/
CNC- Machin à mesurer type 0181

mit max. Verfahrgeschwindigkeit 500 mm/sec
max. speed of movement 500/sec
max. vitesse de mouvement 500/sec



Z-Achse (axis / axe) MB	Y-Achse (axis / axe) MB	Genauigkeits- klasse / Accuracy class/ Classe de précision	Genauigkeits- klasse / Accuracy class/ Classe de précision				
			H1	H2	H3	B4	B8
1000	800	A _S (B)	2100	210	250	185	1420
1200	1000	A _S (B)	2300	210	250	185	1620

() = Genauigkeitsklasse ohne CAA/ Compensation class without CAA/ Classe d'Compensation sans CAA

LL-Länge / Lengh / Longueur	X-Achse (axis / axe) MB
1500	940
2000	1440
2500	1940
3000	2440
3500	2940
4000	3440
4500	3940
5000	4440
5500	4940
6000	5440
7000	6440
8000	7440
9000	8440
10000	9440

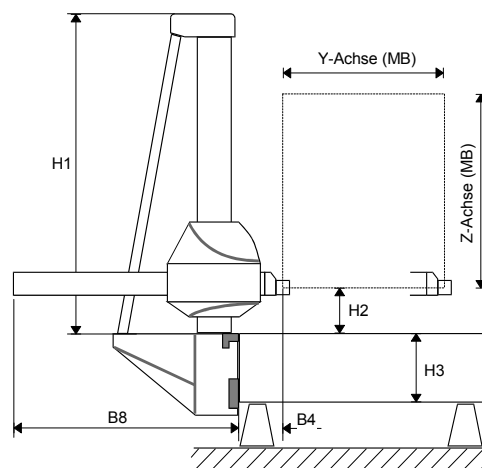

Alle Angaben in mm / All measures in mm / Toutes les mesures sont donnés en mm

LL= Leitlineal / Lengh of Guide Rail / Longueur rail de guidage

MB= Messbereich / measuring range / cours de mesurer

Technische Änderungen vorbehalten! / Technical modification reserved! /
Données techniques susceptibles de modification après impression !

Profi- Konsolenausführung

CNC-Messmaschine Typ 0181,
 DCC- Measuring machine type 0181/
 CNC- Machin à mesurer type 0181

mit max. Verfahrgeschwindigkeit 500 mm/sec
 max. speed of movement 500/sec
 max. vitesse de mouvement 500/sec



Z-Achse (axis / axe) MB	Y-Achse (axis / axe) MB	Genauigkeits- klasse / Accuracy class/ Classe de précision	Genauigkeits- klasse / Accuracy class/ Classe de précision				
			H1	H2	H3	B4	B8
1500	1200	C	2600	210	250	185	1820
1800	1400	D	2900	210	250	185	2020
1800	1600	D	2900	210	250	185	2220
2000	1600	D	3100	210	250	185	2220
2400	1600	G	3500	210	250	185	2220
3000	1600	G	4100	210	350	185	2220
3000	2000	G	4130	225	350	200	2630

LL-Länge / Lengh / Longueur	X-Achse (axis / axe) MB
1500	810
2000	1310
2500	1810
3000	2310
3500	2810
4000	3310
4500	3810
5000	4310
5500	4810
6000	5310
7000	6310
8000	7310
9000	8310
10000	9310

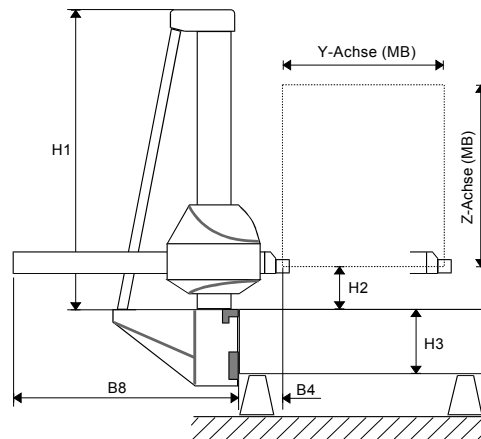

Alle Angaben in mm / All measures in mm / Toutes les mesures sont donnés en mm

LL= Leitlineal / Lengh of Guide Rail / Longueur rail de guidage

MB= Messbereich / measuring range / cours de mesurer

Technische Änderungen vorbehalten! / Technical modification reserved! /
 Données techniques susceptibles de modification après impression !

Profi- Konsolenausführung

CNC-Messmaschine Typ 0181,
DCC- Measuring machine type 0181/
CNC- Machin à mesurer type 0181

mit max. Verfahrgeschwindigkeit 500 mm/sec
max. speed of movement 500/sec
max. vitesse de mouvement 500/sec



**GENAUIGKEITSTABELLE / ACCURY TABLE /
TABLAU DES PRECISIONS:**

Genauigkeits- klasse / Accuracy class/ Classe de précision	MPE _E (µm) ≤ B DIN EN ISO 10360 -2 (U3)	MPE _E (µm) ≤ B Duplex DIN EN ISO 10360 -2	U2 (µm) VDI 2617	U1 (µm) VDI 2617
B	16 + L/100		14 + L/90	12 + L/80
C+D	20 + L/70	50 + L/50 ≤ 150	18 + L/80	15 + L/80
F	25 + L/50 ≤ 100	55 + L/50 ≤ 150	20 + L/70 ≤ 90	18 + L/80 ≤ 80
G	30 + L/50 ≤ 100	60 + L/50 ≤ 150	25 + L/70 ≤ 90	20 + L/80 ≤ 80
J	30 + L/20 ≤ 100	60 + L/50 ≤ 150	25 + L/70 ≤ 90	20 + L/40 ≤ 80
K	45 + L/20 ≤ 100	75 + L/50 ≤ 150	40 + L/70 ≤ 90	35 + L/40 ≤ 80
L	45 + L/20 ≤ 100	75 + L/50 ≤ 150	40 + L/70 ≤ 120	35 + L/25 ≤ 100
M	50 + L/20 ≤ 100	80 + L/50 ≤ 150	45 + L/70 ≤ 120	40 + L/25 ≤ 100
N			Nur achsparallele Messung zulässig	50 + L/15 ≤ 150

**ERHÖHTE GENAUIGKEIT MIT CAA (VOLLKOMPENSATION)/
HIGHER COMPENSATION WITH CAA (FULLCOMPENSATION)/
PLUS HAUTE COMPENSATION AVEC CAA (COMPENSATION COMPLETE)**

Genauigkeits- klasse / Accuracy class/ Classe de précision	MPE _E (µm) ≤ B	MPE _E (µm) ≤ B Duplex
A _s	12 + L/100 ≤ 50	30 + L/100 ≤ 70
C _s -D _s ,F _s	20 + L/100 ≤ 60	35 + L/100 ≤ 80
G _s	25 + L/100 ≤ 60	45 + L/100 ≤ 100

**Technische Änderungen vorbehalten! / Technical modification reserved! /
Données techniques susceptibles de modification après impression !**