

Technische Daten / Technical Data / Dates Techniques

Profi - mit seitlichem Leitlineal / with lateral guide rail / avec rail de guidage latéral

CNC- Messmaschine Typ 0177

DCC- Measuring machine type 0177/

CNC- Machin à mesurer type 0177

max. Verfahrensgeschwindigkeit 250mm/sec

max. speed of movement 250/sec

max. vitesse de mouvement 250/sec



Z-Achse (axis / axe) MB	Y-Achse (axis / axe) MB	Genauigkeits- klasse / Accuracy class/ Classe de précision	H1	H2	H3	B4	B8	B3
800	800	C	2205	320	*	85	920	600
1000	1000	D	2405	320	*	85	1120	600
1200	1200	D	2705	320	*	85	1320	600
1400	1400	F	3005	320	*	85	1520	600
1400	1400	F	3205	320	*	85	1520	600
1600	1600	G	3205	320	*	85	1720	600
1600	1600	G	3605	320	*	85	1720	600
1600	1600	G	4205	320	*	85	1720	600

* = gesonderte Messplatten Liste auf Anfrage/ Additional measures on request/ Autres dimensions sur demande

() = Genauigkeitsklasse ohne CAA/
Compensation class without CAA/
Classe d'Compensation sans CAA

LL-Länge / Lengh / Longueur	X-Achse (axis / axe) MB
1500	850
2000	1350
2500	1850
3000	2350
3500	2850
4000	3350
4500	3850
5000	4350
5500	4850
6000	5350
7000	6350
8000	7350
9000	8350
10000	9350

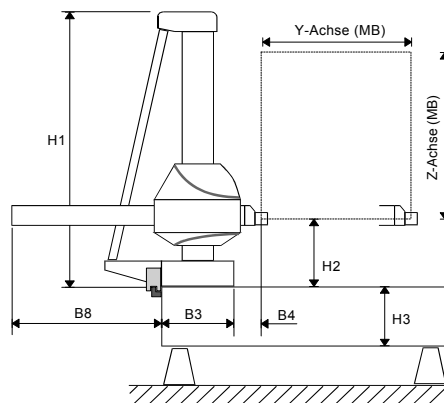

Alle Angaben in mm / All measures in mm /
Toutes les mesures sont donnés en mm

LL= Leitlineal / Lengh of Guide Rail / Longueur rail de guidage

MB= Messbereich / measuring range / cours de mesurer

MB bei Maschinen ohne Bandabdeckung/ measuring range without belt cover/ cours de mesurer de machine sont bande de protection

Technische Änderungen vorbehalten! / Technical modification reserved! /

Données techniques susceptibles de modification après impression !

Technische Daten / Technical Data / Dates Techniques

Profi - mit seitlichem Leitlineal / with lateral guide rail / avec rail de guidage latéral

CNC- Messmaschine Typ 0177

DCC- Measuring machine type 0177/

CNC- Machin à mesurer type 0177

max. Verfahrensgeschwindigkeit 250mm/sec

max. speed of movement 250/sec

max. vitesse de mouvement 250/sec



Z-Achse (axis / axe) MB	Y-Achse (axis / axe) MB	Genauigkeits- klasse / Accuracy class/ Classe de précision	Genauigkeits- klasse / Accuracy class/ Classe de précision					
			H1	H2	H3	B4	B8	B3
3000	1800	G	4265	360	*	-10	1790	800
3000	2000	G	4265	360	*	-10	1990	800
3000	2500	G	4265	360	*	-10	2490	800
4000	2000	J	5265	360	*	-10	1990	800
4000	2500	J	5265	360	*	-10	2490	800

* = gesonderte Messplatten Liste auf Anfrage/ Additional measure machine on request/ Autres machines à mesurer sur demande

LL-Länge / Lengh / Longueur	X-Achse (axis / axe) MB
1500	650
2000	1150
2500	1650
3000	2150
3500	2650
4000	3150
4500	3650
5000	4150
5500	4650
6000	5150
7000	6150
8000	7150
9000	8150
10000	9150

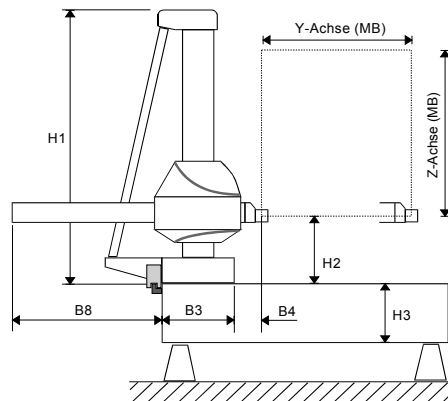

Alle Angaben in mm / All measures in mm /
Toutes les mesures sont donnés en mm

LL= Leitlineal / Lengh of Guide Rail / Longueur rail de guidage

MB= Messbereich / measuring range / cours de mesurer

Technische Änderungen vorbehalten! / Technical modification reserved! /
Données techniques susceptibles de modification après impression !

Technische Daten / Technical Data / Datas Techniques

Profi - mit seitlichem Leitlineal / with lateral guide rail / avec rail de guidage latéral

CNC- Messmaschine Typ 0177

DCC- Measuring machine type 0177/

CNC- Machin à mesurer type 0177

max. Verfahrensgeschwindigkeit 250mm/sec

max. speed of movement 250/sec

max. vitesse de mouvement 250/sec



GENAUIGKEITSTABELLE / ACCURY TABLE / TABLAU DES PRECISIONS:

Genauigkeits- klasse / Accuracy class/ Classe de précision	MPE _E (µm) ≤ B DIN EN ISO 10360 -2 (U3)	MPE _E (µm) ≤ B Duplex DIN EN ISO 10360 -2	U2 (µm) VDI 2617	U1 (µm) VDI 2617
B	16 + L/100		14 + L/90	12 + L/80
C+D	20 + L/70	50 + L/50 ≤ 150	18 + L/80	15 + L/80
F	25 + L/50 ≤ 100	55 + L/50 ≤ 150	20 + L/70 ≤ 90	18 + L/80 ≤ 80
G	30 + L/50 ≤ 100	60 + L/50 ≤ 150	25 + L/70 ≤ 90	20 + L/80 ≤ 80
J	30 + L/20 ≤ 100	60 + L/50 ≤ 150	25 + L/70 ≤ 90	20 + L/40 ≤ 80
K	45 + L/20 ≤ 100	75 + L/50 ≤ 150	40 + L/70 ≤ 90	35 + L/40 ≤ 80
L	45 + L/20 ≤ 100	75 + L/50 ≤ 150	40 + L/70 ≤ 120	35 + L/25 ≤ 100
M	50 + L/20 ≤ 100	80 + L/50 ≤ 150	45 + L/70 ≤ 120	40 + L/25 ≤ 100
N			Nur achsparallele Messung zulässig	50 + L/15 ≤ 150

ERHÖHTE GENAUIGKEIT MIT CAA (VOLLKOMPENSATION)/ HIGHER COMPENSATION WITH CAA (FULLCOMPENSATION)/ PLUS HAUTE COMPENSATION AVEC CAA (COMPENSATION COMPLETE)

Genauigkeits- klasse / Accuracy class/ Classe de précision	MPE _E (µm) ≤ B	MPE _E (µm) ≤ B Duplex
A _s	12 + L/100 ≤ 50	30 + L/100 ≤ 70
C _s -D _s ,F _s	20 + L/100 ≤ 60	35 + L/100 ≤ 80
G _s	25 + L/100 ≤ 60	45 + L/100 ≤ 100

**Technische Änderungen vorbehalten! / Technical modification reserved! /
Données techniques susceptibles de modification après impression !**